

**Fagnano orbits of polygonal dual billiards**

by

**Serge Tabachnikov**

**UofA-R-164**

# Fagnano orbits of polygonal dual billiards

Serge Tabachnikov

Department of Mathematics, University of Arkansas,  
Fayetteville, AR 72701, USA; serge@comp.uark.edu

The aim of this note is to provide a dual billiard counterpart to E. Gutkin's results ([Gu]) on Fagnano billiard orbits. Although the results and proofs in this note are quite elementary I hope to attract the reader's attention to the lesser known dynamical system, the dual (a.k.a. outer) billiard which is, in many ways, similar to, and sometimes easier to study than the conventional billiard.

One plays the game of dual billiard outside (rather than inside) the billiard table. Let the table be a convex polygon  $P$  in the plane and  $x$  a point in its exterior (but not on the continuation of either of its sides). There are two support lines to  $P$  through  $x$ ; choose the right one, as viewed from  $x$ , and reflect  $x$  in the support vertex of  $P$  to obtain the image of  $x$  under the dual billiard map, denoted by  $T$  in figure 1. Clearly, the dual billiard map is a central symmetry in each component of its domain. The infinite orbit of a point  $x$  under this map is defined if none of the images or preimages of  $x$  belongs to the continuation of a side of the polygon  $P$ ; the set of such "good" points has full measure. Notice that the dual billiard map is equivariant under affine transformations of the plane.

Fig. 1

The definition extends to other convex billiard tables (say, ovals); remarkably, the dual billiard map is area preserving. The interested reader is referred to the surveys [Ta 1, 2] where, in particular, he will find an explanation of the duality between usual and dual billiards and a discussion of multi-dimensional dual billiards.

Before going into discussion of Fagnano dual billiard orbits, the actual topic of the note, mention a few facts about polygonal dual billiards. If  $P$  is a rational polygon then every orbit is periodic. For a wider class of polygons, described in [S-V, G-S] and including affine-regular polygons, every orbit of the dual billiard map stays bounded, but it is not known whether this holds true for all polygons (see [Mo]). It is not known either whether the dual billiard map has periodic orbits for every polygon  $P$ . The orbits of the polygonal

dual billiard map can be infinite as illustrated by a regular pentagon in figure 2: the closure of the depicted orbit is a self-similar fractal set.

Fig. 2

Now it is time to introduce the main character of this note. Let  $P = (z_1, z_2, \dots, z_n)$  be a convex  $n$ -gon (whose vertices, cyclically denoted by  $z_i$ , are thought of as complex numbers). A Fagnano orbit of the dual billiard map is an  $n$ -periodic orbit consisting of  $n$  points consecutively reflected in the vertices  $z_1, z_2, \dots, z_n$ . The name is used in analogy with the Fagnano billiard orbit in an acute triangle made of the foot points of the triangle's altitudes.

One distinguishes between odd and even  $n$ . If  $n$  is odd then a composition of  $n$  reflections is again a reflection. A reflection has a unique fixed point, and it follows that a Fagnano orbit is unique (if exists). If  $n$  is even then a composition of  $n$  reflections is a parallel translation that does not have fixed points at all unless it is the identity. The respective translation vector is twice the alternating sum of the vectors  $z_i$ ; thus a necessary condition for a Fagnano orbit to exist is:

$$z_1 - z_2 + z_3 - \dots - z_n = 0.$$

On the other hand, for even  $n$ , Fagnano orbits are never isolated: if  $x$  belongs to such an orbit then every point, sufficiently close to  $x$ , belongs to a Fagnano orbit too.

An example of a polygon without Fagnano orbits is shown in figure 3.

Fig. 3

It is known that billiard trajectories are extrema of the length functional. One wonders what plays the role of length in the dual billiard setting. The answer is: area. Namely, connecting consecutive points of a Fagnano orbit one obtains a convex polygon  $Q$ , circumscribed about the billiard polygon  $P$ .

**Lemma.** *A circumscribed polygon corresponds to a Fagnano orbit if and only if its area is extremal among all such polygons.*

**Proof.** The area of  $Q$  is extremal if and only if it does not change, up to infinitesimals of higher order, under infinitesimal rotations of its sides about the vertices of  $P$ . Consider figure 4: the ratio of the areas of the triangles  $BAB'$  and  $CAC'$  equals  $AB^2/AC^2$ , again up to infinitesimals of higher order. Thus the areas of the infinitesimal triangles are equal if and only if  $AB = AC$ .

Fig. 4

Of course the lemma also applies to self-intersecting circumscribed polygons and describes periodic orbits of the dual billiard map, other than Fagnano ones. The area should be computed accordingly: each component of the complement of  $Q$  is taken with the multiplicity, equal to the number of turns made by  $Q$  about a point of this component. An example is shown in figure 5. Mention in passing that the area extremum is neither local minimum nor maximum: for example, if  $P$  is a triangle then the Hessian of the area function on circumscribed triangles has the signature  $(+ + -)$  at the Fagnano orbit.

Fig. 5

An immediate consequence of the lemma is that if, for an even  $n$ , Fagnano polygons exist then they all have the same areas: indeed a function is constant on its critical manifold. Thus, given a billiard polygon  $P$ , if there exists a Fagnano polygon  $Q$  then its area is well defined. Under the existence assumption we address the following question: *for which  $n$ -gons  $P$  does the ratio  $\text{Area}(Q)/\text{Area}(P)$  have the minimal value?* An analogous question for Fagnano billiard trajectories was studied in [Gu] (with areas replaced by perimeters and minimum by maximum – another manifestation of duality between usual and dual billiards!), and the extremal polygons were proved to be the regular ones.

If  $n = 3$  or  $4$  there is nothing to investigate: the ratio does not depend on  $P$ . For a triangle it equals 4, and for a quadrilateral, that must be a parallelogram for a Fagnano orbit to exist, it equals 2. The first nontrivial case is that of  $n = 5$ . The answer is as follows.

**Theorem 1.** *The ratio  $\text{Area}(Q)/\text{Area}(P)$  attains its minimum when  $P$  is an affine-regular polygon. This minimum equals  $1/\cos^2(\pi/n)$ .*

**Proof.** Let  $Q$  be a Fagnano polygon whose vertices are oriented counterclockwise. The respective billiard polygon  $P$  is the image of the medial map

$$\mu : Q(w_1, w_2, \dots, w_n) \rightarrow P(z_1, z_2, \dots, z_n); \quad z_i = (w_i + w_{i+1})/2.$$

Consider  $w_i$  as independent variables. The area of  $Q$  is given by the formula

$$\frac{1}{2} \operatorname{Im} \sum_1^n \bar{w}_i w_{i+1}$$

and that of  $P$  by

$$\frac{1}{2} \operatorname{Im} \sum_1^n \bar{z}_i z_{i+1} = \frac{1}{2} \operatorname{Area}(Q) + \frac{1}{8} \operatorname{Im} \sum_1^n \bar{w}_i w_{i+2}.$$

Consider the space of  $n$ -gons (i.e., ordered  $n$ -tuples of points) as  $\mathbb{C}^n$  and reduce the (complex) dimension by 1 restricting to polygons with the center of mass at the origin. Then  $\mu$  is a linear map of this space; for odd  $n$  it is an isomorphism and for even  $n$  its kernel is one-dimensional. The first of the above formulas gives the algebraic area of a polygon; for example, it assigns a negative area to a clockwise oriented simple polygon.

Our problem is to find the relative extrema of the two quadratic forms:

$$A_1 = \text{Im} \sum_1^n \bar{w}_i w_{i+1}, \quad A_2 = \text{Im} \sum_1^n \bar{w}_i w_{i+2}.$$

The relative extrema are attained on the common eigen-spaces. One wants to find a basis in which both forms diagonalize.

Let  $q = \exp(2\pi\sqrt{-1}/n)$  be the  $n$ -th primitive root of unity. Consider the vectors

$$X_i = (1, q^i, q^{2i}, \dots, q^{i(n-1)}), \quad i = 1, \dots, n-1;$$

these vectors constitute a basis of our space of polygons. For  $i = 1$  or  $n-1$  these vectors describe regular  $n$ -gons (with the opposite orientations); for other values of  $i$  these are self-intersecting regular polygons ("stars"), possibly multiply-covered.

One has:

$$A_1(\sum c_i X_i) = n \sum |c_i|^2 \text{Im} q^i = n \sum |c_i|^2 \sin \frac{2\pi i}{n},$$

$$A_2(\sum c_i X_i) = n \sum |c_i|^2 \text{Im} q^{2i} = n \sum |c_i|^2 \sin \frac{4\pi i}{n},$$

as readily follows from the formulas

$$\sum_i q^{ik} = 0 \quad \text{for } k \neq 0 \quad \text{and} \quad \sum_i q^{ik} = n \quad \text{for } k = 0.$$

Thus  $X_i$  is the desired basis.

The relative extrema of the two quadratic forms are the ratios of the eigen-values of  $A_2$  and  $A_1$ :

$$\frac{\sin \frac{4\pi i}{n}}{\sin \frac{2\pi i}{n}} = 2 \cos \frac{2\pi i}{n}, \quad i = 1, \dots, n-1.$$

The greatest of these numbers is  $2 \cos(2\pi/n)$ , and this ratio is attained on the subspace generated by  $X_1$  and  $X_{n-1}$ . One has:

$$\frac{\text{Area}(Q)}{\text{Area}(P)} = \frac{4A_1(Q)}{2A_1(Q) + A_2(Q)},$$

and it follows that

$$\min_P \frac{\text{Area}(Q)}{\text{Area}(P)} = \frac{2}{1 + \cos \frac{2\pi}{n}} = \frac{1}{\cos^2 \frac{\pi}{n}}.$$

To finish the proof it remains to notice that the space of affine-regular  $n$ -gons centered at the origin coincides with the space generated by  $X_1$  and  $X_{n-1}$ . Indeed, the real dimensions of both spaces equal 4, and the latter contains the former since the ratio  $\text{Area}(Q)/\text{Area}(P)$  for an affine-regular  $n$ -gon is the same as for a regular one.

One can derive the following description of the dynamics of the medial map  $\mu$  from the above proof. Let  $Q$  be an  $n$ -gon (not necessarily convex or simple).

**Theorem 2.** *The polygons  $\mu^k(Q)$  converge to the centroid of  $Q$  as  $k \rightarrow \infty$ . If  $Q$  is generic (does not belong to a codimension 2 subspace) then, considered up to affine transformations,  $\lim_{k \rightarrow \infty} \mu^k(Q)$  is a regular  $n$ -gon. In particular, the latter holds for every convex polygon  $Q$ .*

**Proof.** Using the previous notation, one has:  $\mu(X_i) = 0.5(1 + q^i) X_i$ . The absolute values of these eigen-values are less than 1, therefore the iterations of  $\mu$  converge to the origin, that is, the centroid of  $Q$ .

The maximum of the numbers  $|(1 + q^i)/2|$  is attained for  $i = 1$  and  $n - 1$ . Therefore the rate of convergence to the origin is the slowest on the subspace generated by  $X_1$  and  $X_{n-1}$ , that is, the space of affine-regular polygons. Therefore if  $Q$  does not lie in the subspace spanned by  $X_i$  with  $i \neq 1, n - 1$  then the limiting shape of the polygons  $\mu^k(Q)$  is that of an affine-regular  $n$ -gon.

Finally, assume that a convex polygon  $Q$  lies in the subspace spanned by  $X_i$  with  $i \neq 1, n - 1$ . Let  $j \geq 2$  be the least number such that the decomposition of  $Q$  with respect to the basis  $X_i$  contains a non-trivial linear combination of  $X_j$  and  $X_{n-j}$ . Then, as before, the limiting shape of  $\mu^k(Q)$  is determined by this combination of  $X_j$  and  $X_{n-j}$ . Arguing as in the proof of Theorem 1, the space generated by  $X_j$  and  $X_{n-j}$  consists of the polygons affine equivalent to  $X_j$ . In particular, these polygons are not convex. This contradicts to the obvious fact that  $\mu^k(Q)$  is convex for every  $k$ .

**Remark.** One can consider the limit of the space of  $n$ -gons,  $n \rightarrow \infty$ , to be the space of (sufficiently smooth) complex-valued functions on the circle. In this limit, the polygons  $X_j$  and  $X_{n-j}$  become the  $j$ -th harmonics  $\exp(\pm \sqrt{-1}j\alpha)$ , the decomposition of a polygon in the basis  $X_i$  becomes the Fourier expansion, and the property of a polygon to intersect the vertical axis in  $2j$  points becomes the property of the real part of a function to have  $2j$  zeroes.

We proved that a convex  $n$ -gon does not lie in the subspace, spanned by  $X_i$  with  $i \neq 1, n-1$ . One can prove more: if  $j$  is the least number such that the decomposition of an  $n$ -gon  $Q$  with respect to the basis  $X_i$  contains a non-trivial linear combination of  $X_j$  and  $X_{n-j}$  then  $Q$  intersects the vertical axis (and any other line through the origin) at least  $2j$  times. This follows from the observation that the number of intersections of  $\mu(Q)$  with the axis is not greater than that of  $Q$ .

The statement (and its proof) has the following continuous version: a real function  $F$  on the circle whose Fourier expansion starts with  $j$ -th harmonics has at least  $2j$  distinct zeroes (A. Hurwitz, [Hu]). A proof, similar to the above argument, goes as follows. Consider  $F$  as the initial data for the heat equation  $F_t = F_{\alpha\alpha}$ . By the maximum principle, the number of zeroes does not increase as  $t$  grows. Since higher harmonics die off faster than the first nontrivial one, the limit function for  $t \rightarrow \infty$  has  $2j$  zeroes – see [Ar].

Conclude with a question. One can play the game of dual billiard in the spherical or hyperbolic geometry as well as in the Euclidean plane. Do the results of this note extend in this setting? The lemma still applies, and I think that the results of the theorems also hold true (notice that the notion of the centroid is available in the geometries of constant curvature).

**Acknowledgment.** I am grateful to E. Gutkin for his interest and stimulating questions.

## References

[Ar] V. Arnold. Topological problems of wave propagation. Russ. Math. Surv., 51, No 1, (1996), 3-50.

[Gu] E. Gutkin. The Fagnano billiard orbit and an extremal property of regular polygons. Preprint.

[G-S] E. Gutkin, N. Simanyi. Dual polygonal billiards and necklace dynamics. Comm. Math. Phys., 143, (1991), 431-450.

[Hu] A. Hurwitz. Über die Fourieschen Konstanten integrierbarer Funktionen. Math. Ann., 57, (1903), 425-446.

[Mo] J. Moser. Is the Solar system stable? Math. Intell., 1, (1978), 65-71.

[S-V] A. Shaidenko, F. Vivaldi. Global stability of a class of discontinuous dual billiards. Comm. Math. Phys., 110, (1987), 625-640.

[Ta 1] S. Tabachnikov. Dual billiards. Russ. Math. Surv., 48, No 6 (1993), 75-102.

[Ta 2] S. Tabachnikov. Billiards. SMF "Panoramas et Syntheses", N 1, 1995.

## Figure Captions

Figure 1. Polygonal dual billiard map.

Figure 2. An infinite orbit of the dual billiard map.

Figure 3. Pentagon  $P$  does not have Fagnano orbits.

Figure 4. Proof of the area extremizing property of closed orbits.

Figure 5. Algebraic area of a self-intersecting polygon.

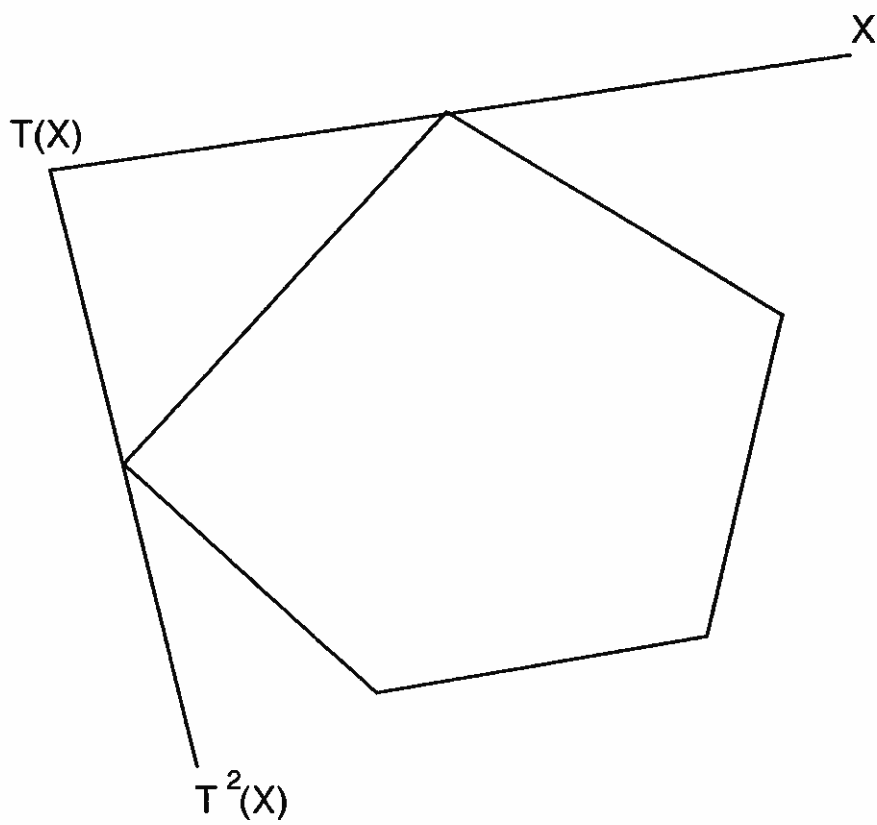

Figure 1

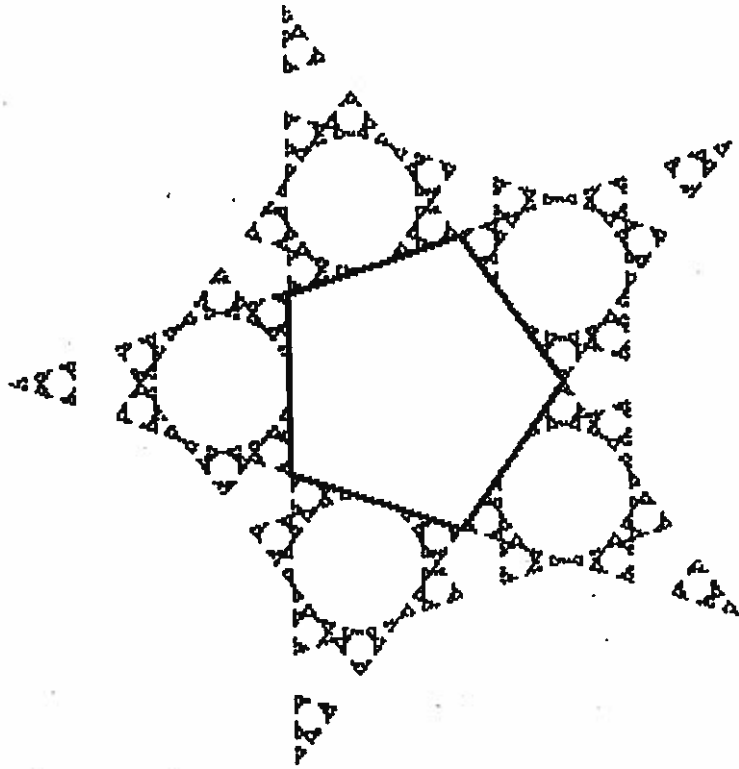

Figure 2

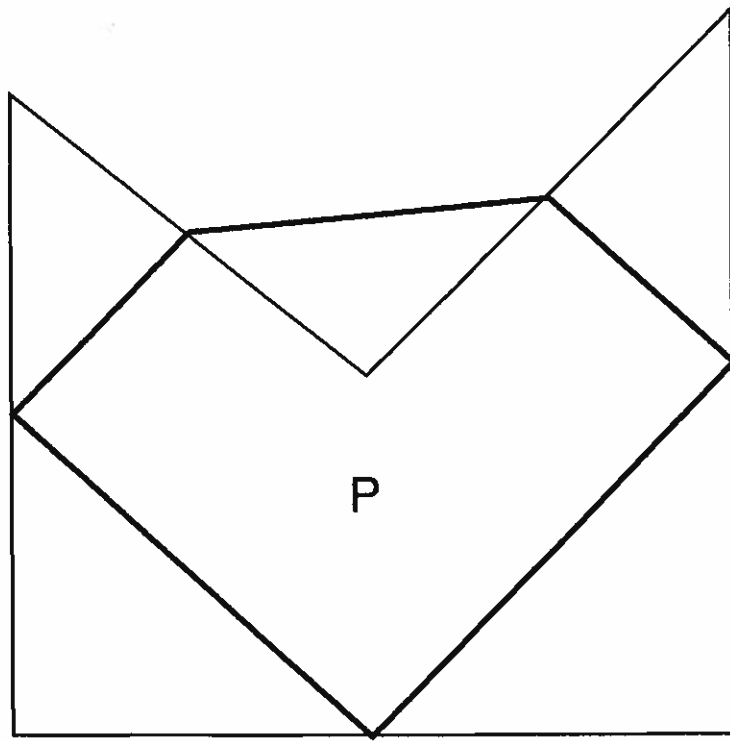

Figure 3

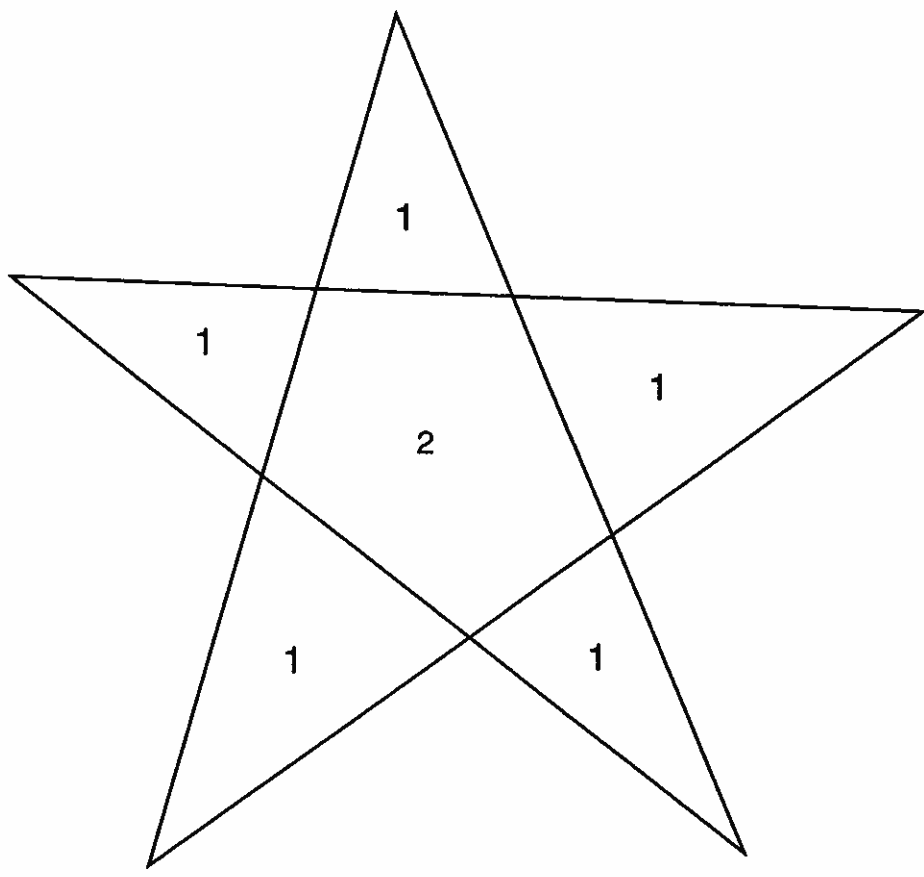

Figure 5

**Department of Mathematical Sciences  
University of Arkansas, Research Reports**

No. 149	Hypersurface Sections of Modules	Mark R. Johnson	Sept. '97
No. 150	Serre's Condition $R_k$ for Associated Graded Rings	Mark R. Johnson and Bernd Ulrich	Sept. '97
No. 151	Nonabelian Integrable Systems, Quasideterminants, and Marchenko Lemma	Pavel Etingof, Israel Gelfand, and Vladimir Retakh	Sept. '97
No. 152	Second-order Cohomology Groups of Semigroup Algebras	H. G. Dales and J. Duncan	Oct. '97
No. 153	A Fuchs-type Theorem for Partial Differential Equations	Jill E. Hemmati	Oct. '97
No. 154	Quasideterminants, I	I. Gelfand and V. Retakh	Oct. '97
No. 155	Nonlinear Carleman Operators on Banach Lattices	William Feldman	Oct. '97
No. 156	Piecewise-Smooth Surfaces as the Union of Geodesic Disks	Chaim Goodman-Strauss	Oct. '97
No. 157	On A Generalized Reflection Law For Functions Satisfying The Helmholtz Equation	Dawit Aberra	Nov. '97
No. 158	The Dual of Bergman Metric VMO	Daniel H. Luecking	Jan. '98
No. 159	Bounded Composition Operators with Closed Range on the Dirichlet Space	Daniel H. Luecking	Jan. '98
No. 160	An aperiodic pair of tiles in $E^n$ for all $n \geq 3$	Chaim Goodman-Strauss	Feb. '98
No. 161	Projectively equivalent metrics, exact transverse line fields and the geodesic flow on the ellipsoid	Serge Tabachnikov	Mar. '98
No. 162	Best Approximation in the Mean by Analytic and Harmonic Functions	Dmitry Khavinson, John E. McCarthy, and Harold S. Shapiro	May '98
No. 163	Plemelj Projection Operators over Domain Manifolds	John Ryan	May '98
No. 164	Fagnano orbits of polygonal dual billiards	Serge Tabachnikov	May '98